

RF ESD Protection Diodes

- ESD protection of RF antenna / interfaces or ultra high speed data lines acc. to:
IEC61000-4-2 (ESD): ± 20 kV (air / contact)
IEC61000-4-4 (EFT): 40 A (5/50 ns)
IEC61000-4-5 (surge): 10 A (8/20 μ s)
- Very low line capacitance: 0.8 pF @ 1 GHz
(0.4 pF per diode)
- Ultra low series inductance: 0.4 nH per diode
- Very low clamping voltage
- Ultra small leadless package 1.2 x 0.8 x 0.39 mm
- Pb-free (RoHS compliant) package
- Qualified according AEC Q101

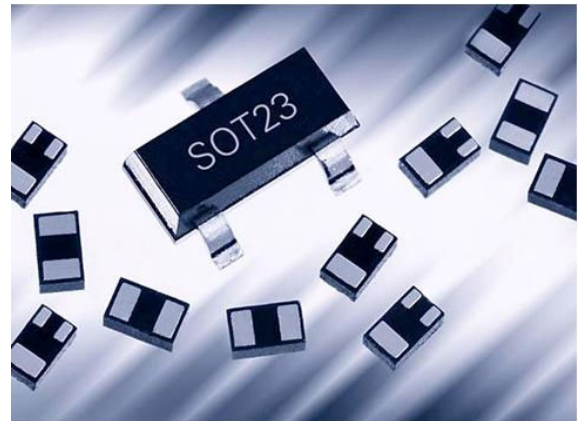

Applications in anti-parallel configuration

- For low RF signal levels without superimposed DC voltage: e.g. GPS, XM-Radio, Sirius, DVB, DMB, DAB, Remote Keyless Entry

Applications in rail-to-rail configuration

- For high RF signal levels or low RF signal levels with superimposed DC voltage: e.g. HDMI, S-ATA, Gbit Ethernet



ESD0P8RFL

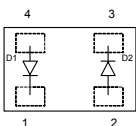

Type	Package	Configuration	Marking
ESD0P8RFL	TSLP-4-7	anti-parallel	E8

Maximum Ratings at $T_A = 25^\circ\text{C}$, unless otherwise specified

Parameter	Symbol	Value	Unit
ESD contact discharge ¹⁾	V_{ESD}	20	kV
Peak pulse current ($t_p = 8 / 20 \mu\text{s}$) ²⁾	I_{pp}	10	A
Operating temperature range	T_{op}	-55...150	°C
Storage temperature	T_{stg}	-65...150	

Electrical Characteristics at $T_A = 25^\circ\text{C}$, unless otherwise specified

Parameter	Symbol	Values			Unit
		min.	typ.	max.	
Characteristics					
Reverse working voltage ³⁾	V_{RWM}	-	-	50	V
Reverse current ³⁾ $V_R = 50 \text{ V}$	I_R	-	-	100	nA
Forward clamping voltage ²⁾ $I_{\text{pp}} = 10 \text{ A}$	V_{FC}	-	12	15	V
Line capacitance ⁴⁾ $V_R = 0 \text{ V}, f = 1 \text{ GHz}$	C_T	-	0.8	-	pF
Series inductance (per diode)	L_S	-	0.4	-	nH

¹⁾ V_{ESD} according to IEC61000-4-2, only valid in anti-parallel or rail-to-rail connection.

Please refer to the application examples.

²⁾ I_{pp} according to IEC61000-4-5, only valid in anti-parallel or rail-to-rail connection.

Please refer to the application examples.

³⁾Only valid in rail-to-rail configuration with $V_{\text{CC}} \geq V_{\text{RWM}}$

⁴⁾Total capacitance line to ground (2 diodes in parallel)

Forward clamping voltage $V_{FC} = f(I_{PP})$

$t_p = 8 / 20 \mu s$

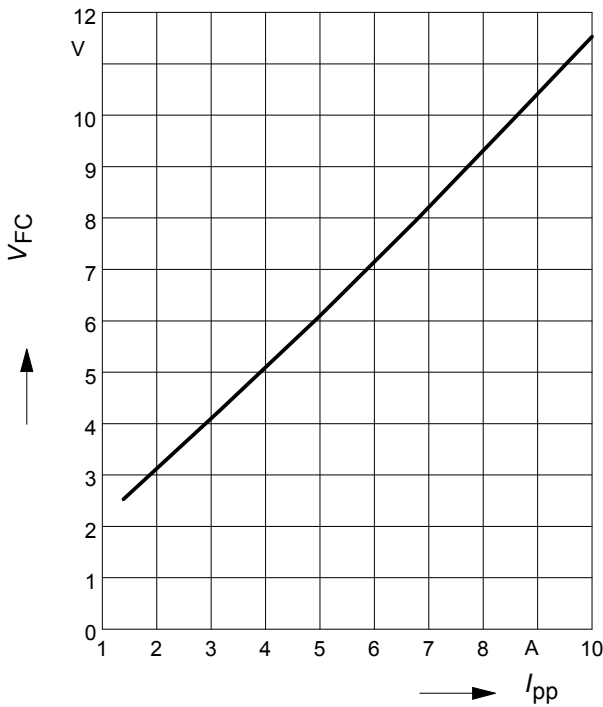

Reverse current $I_R = f(V_R)$

$T_A = \text{Parameter}$

leakage in rail-to-rail configuration

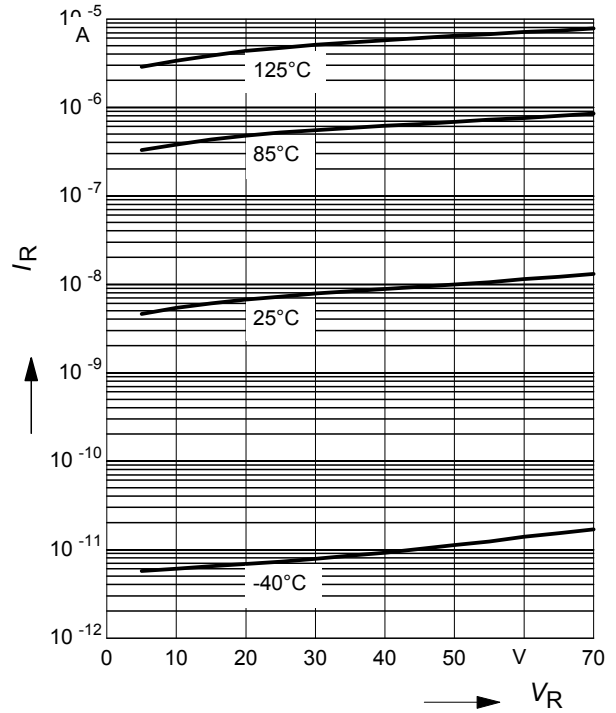

Forward current $I_F = f(V_F)$

$T_A = \text{Parameter}$

leakage in anti-parallel configuration

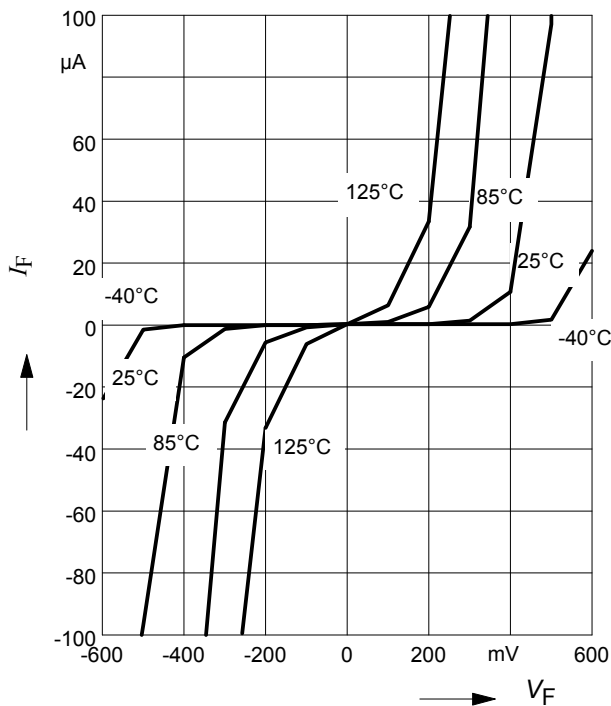

Insertion loss $I_L = -|S_{21}|^2 = f(f)$

$V_R = 0 V, Z = 50 \Omega$

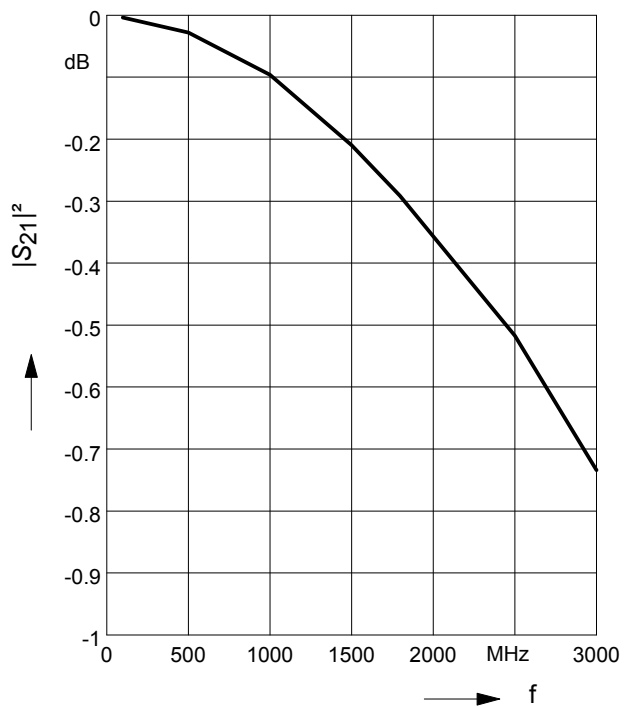

1. Application example ESD0P8RFL

1 RF signal channel, anti-parallel configuration

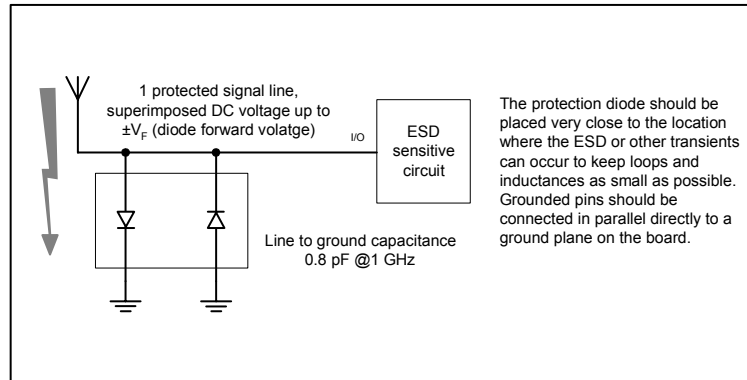

2. Application example ESD0P8RFL

1 RF signal channel, rail-to-rail configuration

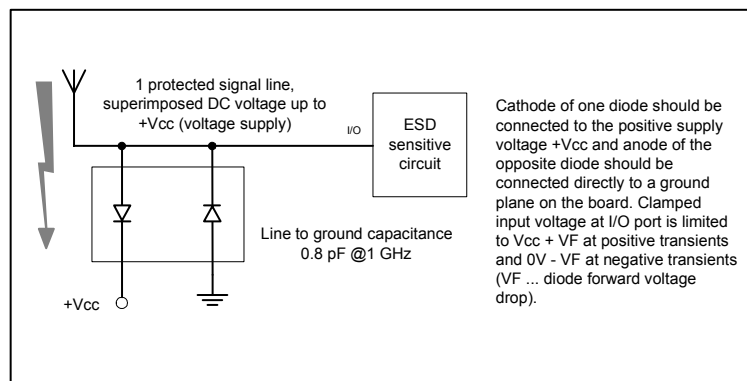

Test setup for ESD clamping voltage

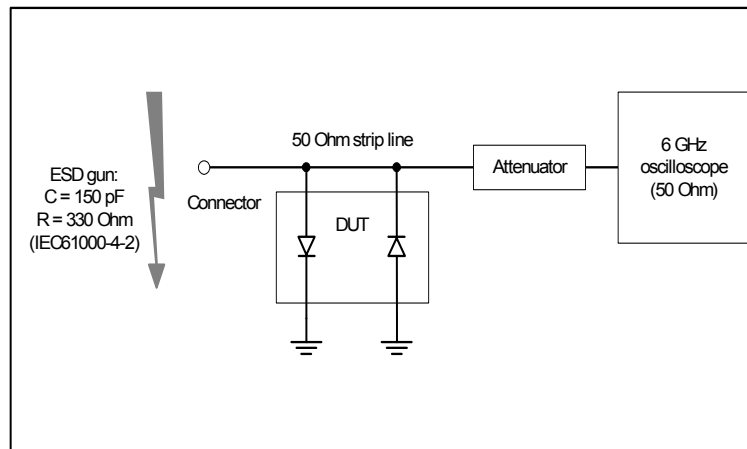

Clamping voltage at real ESD event according to IEC61000-4-2, 8 kV contact discharge

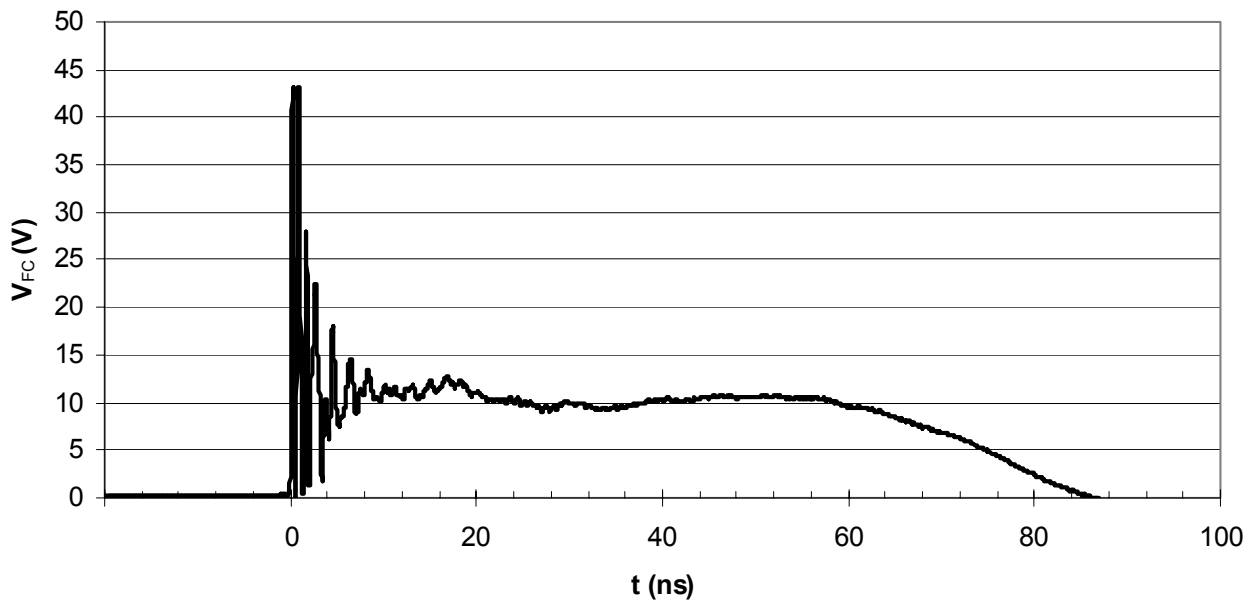

Package Outline

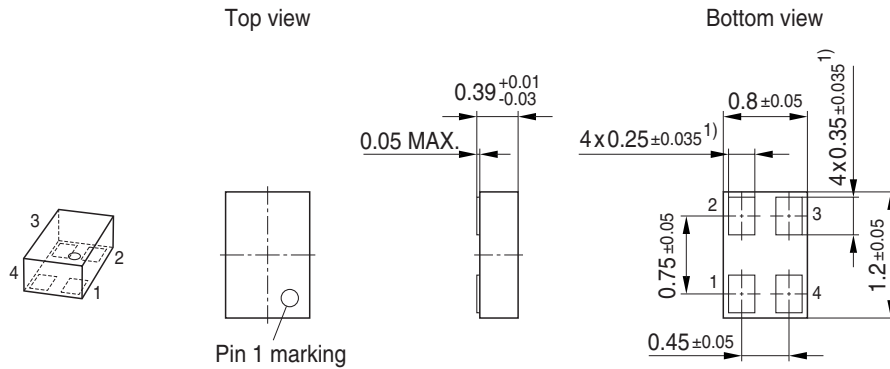

1) Dimension applies to plated terminal

Foot Print

For board assembly information please refer to Infineon website "Packages"

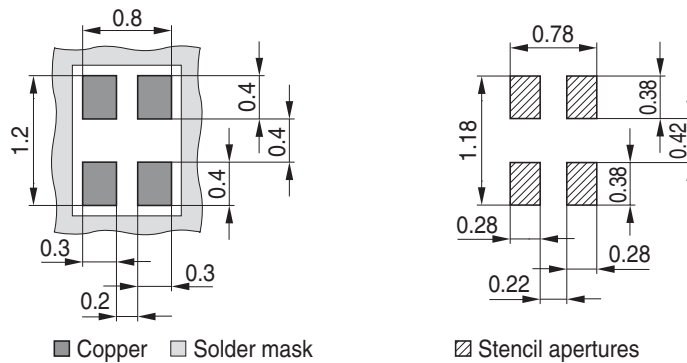

Marking Layout (Example)

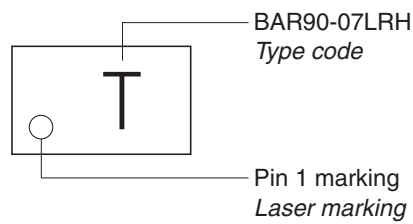

Standard Packing

Reel ø180 mm = 15.000 Pieces/Reel

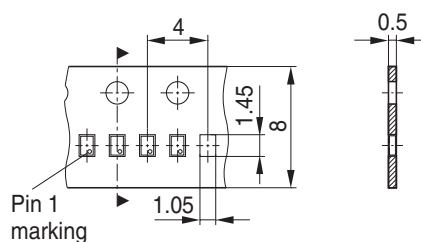

Edition 2006-02-01

Published by

Infineon Technologies AG

81726 München, Germany

© Infineon Technologies AG 2007.

All Rights Reserved.

Attention please!

The information given in this dokument shall in no event be regarded as a guarantee of conditions or characteristics ("Beschaffheitsgarantie"). With respect to any examples or hints given herein, any typical values stated herein and/or any information regarding the application of the device, Infineon Technologies hereby disclaims any and all warranties and liabilities of any kind, including without limitation warranties of non-infringement of intellectual property rights of any third party.

Information

For further information on technology, delivery terms and conditions and prices please contact your nearest Infineon Technologies Office (www.infineon.com).

Warnings

Due to technical requirements components may contain dangerous substances. For information on the types in question please contact your nearest Infineon Technologies Office.

Infineon Technologies Components may only be used in life-support devices or systems with the express written approval of Infineon Technologies, if a failure of such components can reasonably be expected to cause the failure of that life-support device or system, or to affect the safety or effectiveness of that device or system.

Life support devices or systems are intended to be implanted in the human body, or to support and/or maintain and sustain and/or protect human life. If they fail, it is reasonable to assume that the health of the user or other persons may be endangered.